

# GEARSKIVING

The new performance standard

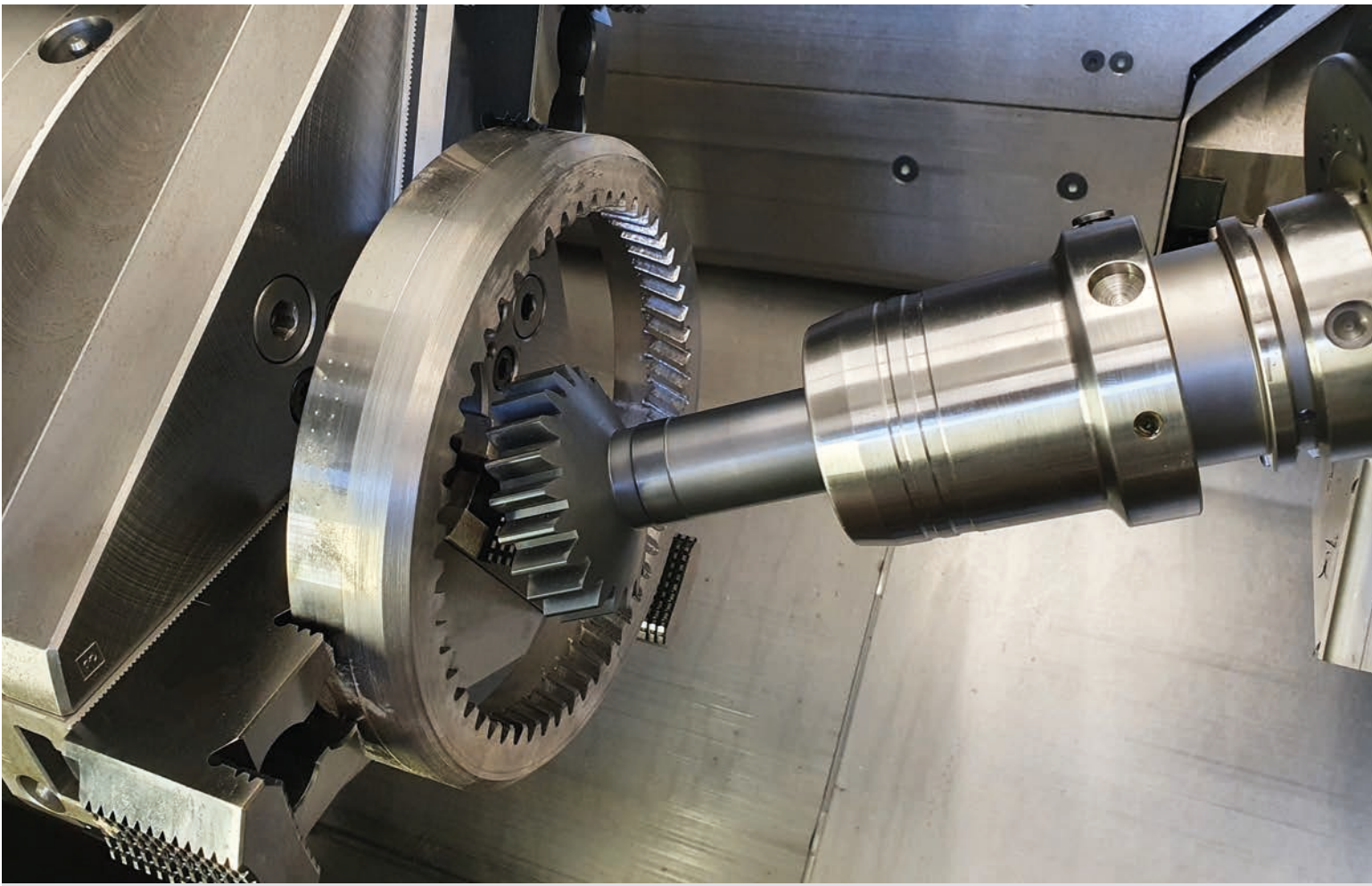

# Highly efficient tool solutions for skiving

Skiving is an extremely efficient technology for the production of internal and external gears, but it places high demands on the tools used.

With its efficiency, performance strength and range of applications, it offers great potential. For example, machining times are faster than for gear shaping, there are broader application possibilities than for gear hobbing and, due to lower tool costs and the elimination of special machines, also compared to broaching. Thanks to the development of more stable machines with synchronized spindles, gear skiving is now becoming accessible to a wider range of uses.

With the new GearSkiving program, LMT Fette supplies process-reliable tools for skiving that guarantee top performance thanks to the special combination of excellent cutting edge preparation and individual process simulation.

## **Advantages of skiving:**

- Reduced machining time compared to gear shaping
- Lower tool costs and elimination of special machines compared to broaching
- Wider range of manufacturable gear components compared to hobbing

# GEARSKIVING

## Powerful and versatile

### Your advantages:

- Fast and individual development of the tool
- Safe and successful tool use through simulation
- Stable production process
- Longer tool life, thanks to excellent cutting edge preparation



Shank tool



Hub type

### Optimally matches to the process

Gear skiving requires particularly durable and high-performance cutting edges because the continuously changing machining conditions lead to very high stress on the tool cutting edge. LMT Fette therefore relies on an innovative process for gear skiving cutting edge preparation. Targeted rounding ensures greater ease of cutting and also has a positive effect on wear behavior and thus tool life. In combination with a specially designed cutting geometry, a protective hard coating and a substrate made of powder metallurgical steel, the customized tool solutions set standards in terms of efficiency and machining reliability.



### Safe and successful tool use thanks to simulation

Parameters such as number of teeth, module, process angle, material, production quantity and valuable experience values are entered into the simulation software. Depending on how the angular ratios and forces are represented in the simulation, the data from the tool is changed and the ideal condition can be achieved. The ideal tool can already be developed and created in advance during the simulation process, since the complex multi-cutting strategies typical of the process often result in a time-consuming path to the final good part. This creates reliability and leads to more efficient tool and process layouts.

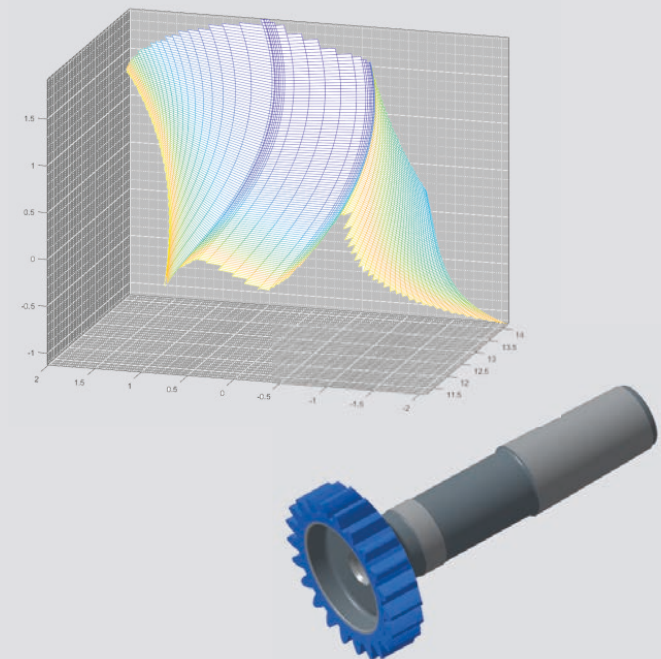

#### Imprint

Publisher: LMT Tools Global Operations GmbH & Co. KG  
 Vogesenstrasse 23, 77933 Lahr, Germany, Phone: +49 78 21 943-0  
 Responsible in the sense of the P: Norman Winter, LMT Tools GmbH & Co. KG  
 Design: hsn – Die Agentur für integrierte Kommunikation GmbH, Hamburg  
 Printing: Druckerei Weidner GmbH, Rostock

© LMT Tools Global Operations GmbH & Co. KG;

This publication may not be reprinted in whole or part without our express permission. All right reserved. No rights may be derived from any errors in content or from typographical or typesetting errors. Diagrams, features and dimensions represent the current status on the date of issue of this catalog. We reserve the right to make technical changes. The visual appearance of the products may not necessarily correspond to the actual appearance in all cases or in every detail.

Sources: LMT Tools Global Operations GmbH & Co. KG and LMT Tool Systems GmbH & Co. KG; P.5 AdobeStock





Combine flexibility and productivity  
in the production of internal and  
external gears.

- High-precision cutting wheels  
of the highest quality
- For internal and external gears  
module 0,8 bis 8 mm

